

STEERING GEAR SYSTEMS



**Proven Reliability
for Naval Operations**



Jered has supplied steering gear for most classes of US Navy ships and numerous foreign navy vessels, ensuring critical safety and operational reliability.

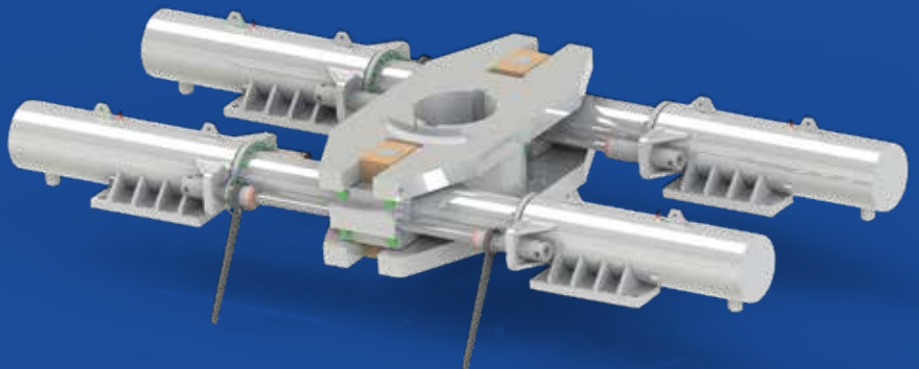

STEERING GEAR SYSTEMS



Unmatched Performance

Our hydraulic ram-type steering gear is trusted by the US surface combatant fleet for its proven reliability and multi-layered fail-safe operation. Available in single or dual rudder-tiller configurations, this system meets the demanding needs of modern naval vessels.



KEY BENEFITS

Steering designs range from simple tiller and link to full shock qualified, fully redundant rapson slide design, providing.

- High torque capability
- Redundant fail-safe operation
- High reliability
- Patented mechanical differential Feedback control
- Low power input and output ratio

OUR LOCATIONS

Jered, LLC | 3000 Sidney Lanier Drive | Brunswick, GA 31525 | Tel: + 1 912.262.2000

San Diego, CA

Norfolk, VA
Brunswick, GA

Windsford, UK

For more information or to contact us please visit jered.com

OUR FAMILY OF BRANDS

